

# **GWALIOR GLORY SCHOOL**

## **SUMMER HOLIDAY HOMEWORK ENGLISH (2025-26)**

**Class : III**

**Name : \_\_\_\_\_ Sec. : \_\_\_\_\_ Roll No. : \_\_\_\_\_ Date : \_\_\_\_\_**

### **Q1. Reading Comprehension: The Red Dress**

Priya's mother got her a new dress for her birthday. The dress was red in colour. It also had flowers at the bottom. These flowers were blue, green and white. Priya said to her mother, "This is the best birthday surprise ever, thank you so much!" Her mother said, "I'm very glad you liked the gift."

Priya loved this dress and wore it for her party. She looked beautiful. All her friends asked about her dress. Priya was very happy.

The next day, when she was looking outside her window she saw something which made her very sad. She saw a young girl, around her age, who was cleaning bowls and helping her mother make dinner. Priya would see this girl from her window every day.

One day, she decided to take her red dress and gave it to the girl. The girl had tears of joy and said, "Thank you so much, this is the best surprise ever!" this reminded Priya of what she had said to her mother on her birthday.

When she reached home, she told her mother the story. She said "I'm sorry that I had to give away your gift mom". Her mother gave her a big hug and said, "I'm very proud of you Priya." She also told Priya that this act was the best return gift she could have ever got. This made Priya feel good about herself again.

#### **Answer the following questions:**

**1) What colours were the flowers on the dress?**

---

---

**2) What did Priya see from her window?**

---

---

**3) What did Priya do?**

---

---

**4) What did Priya's mother do?**

---

---

Q2. FIND A WORD!

	item in a home	verb	a food	feeling	an animal
example T	table	tap	taco	tired	turtle
F					
E					
A					
S					
T					

**Q3. Singular and plural nouns.**

Direction write the plural of the words given in the boxes according to the rules.

The worksheet contains the following sections:

- Top Left:** A honeycomb pattern with the rule "Add S".
- Top Right:** A honeycomb pattern with the rule "Add ies".
- Middle Left:** A honeycomb pattern with the rule "Add es".
- Middle Right:** A honeycomb pattern with the rule "No change".
- Bottom Left:** A honeycomb pattern with the rule "Add ves".
- Bottom Center:** A honeycomb pattern with the rule "irregular nouns".

At the bottom, there are two dashed boxes containing lists of words:

apple	man	leaf	candy
mango	ox	student	shirt
tooth	fish	watch	wife
mouse	city	elf	deer
baby	series	hoof	

Sheep	box	cherry	boy
Foot	knife	dish	bag
Monkey	thief	fly	bus
Woman	dress	country	

**Q4. Look carefully at these two pictures.**

Spot any five differences. Describe the differences in proper sentences using a/ an and the correctly. [Colour the picture too!]

**Eg.: The sun is missing in picture 2.**

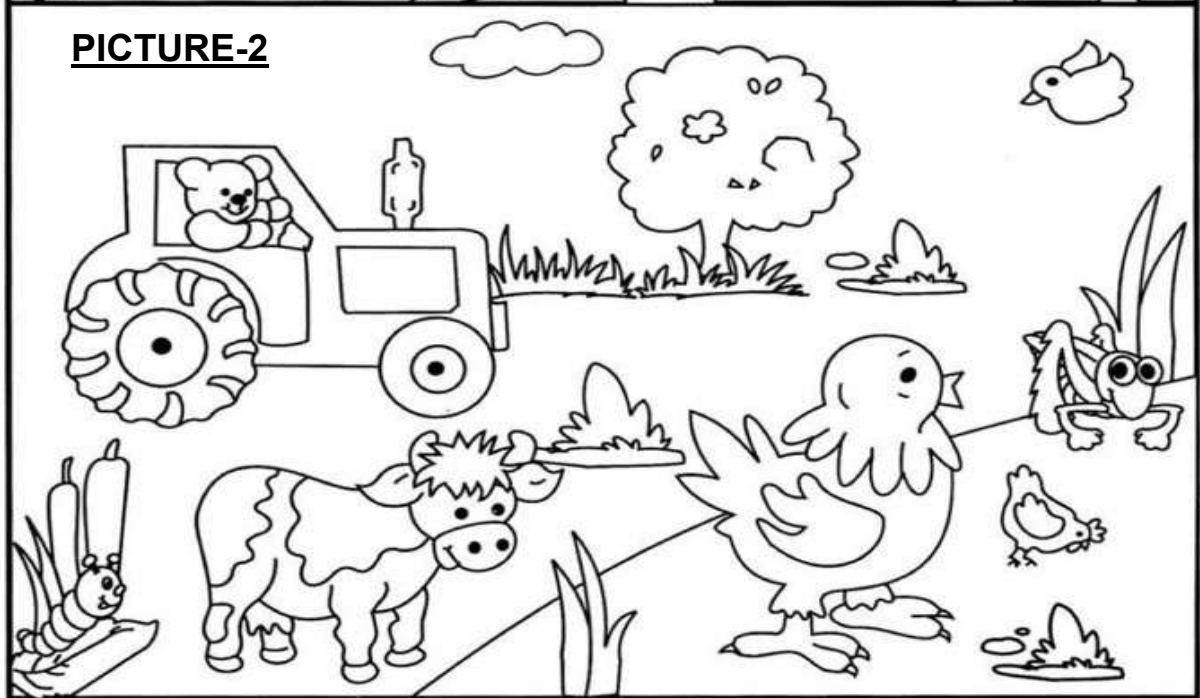
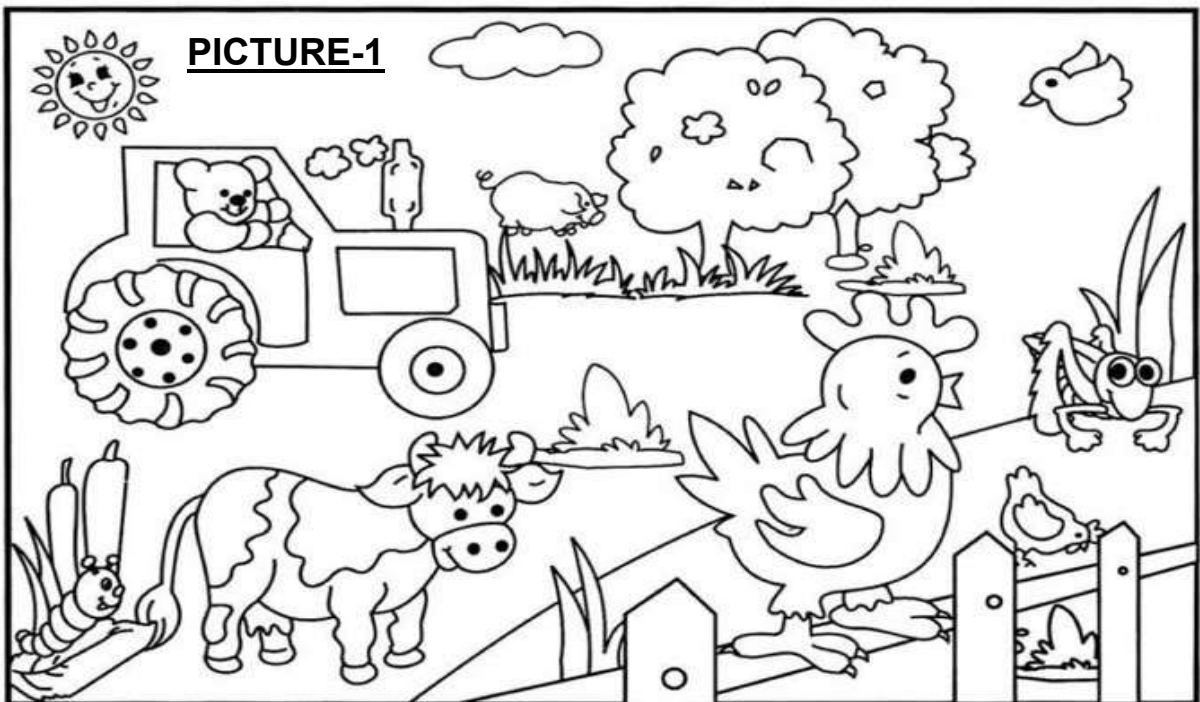

---

---

---

---

---

**Q5. Antonyms or Synonyms**

Read the words on the presents. If they are synonyms, colour the presents red. If they are antonyms, colour the presents blue.

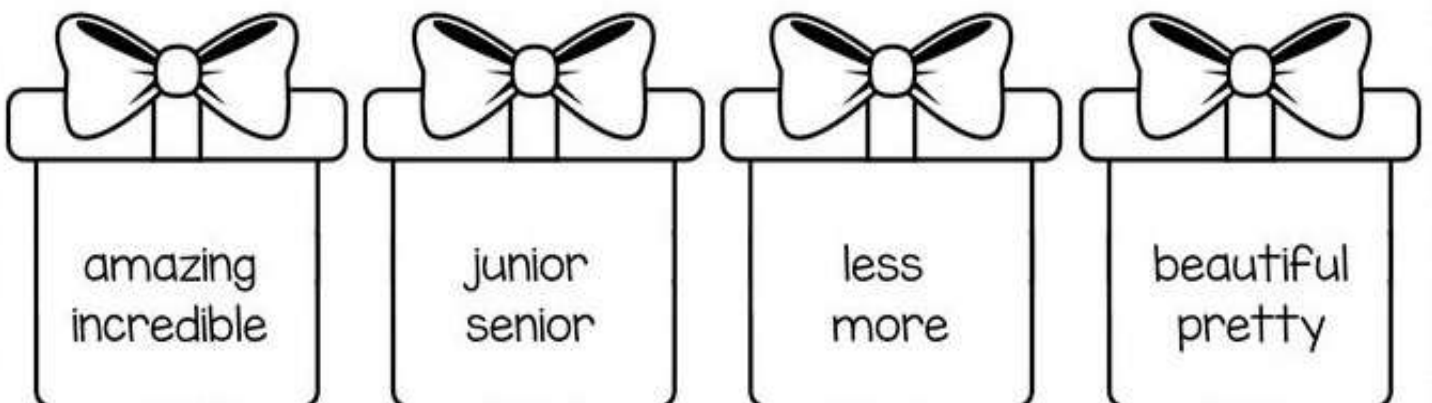
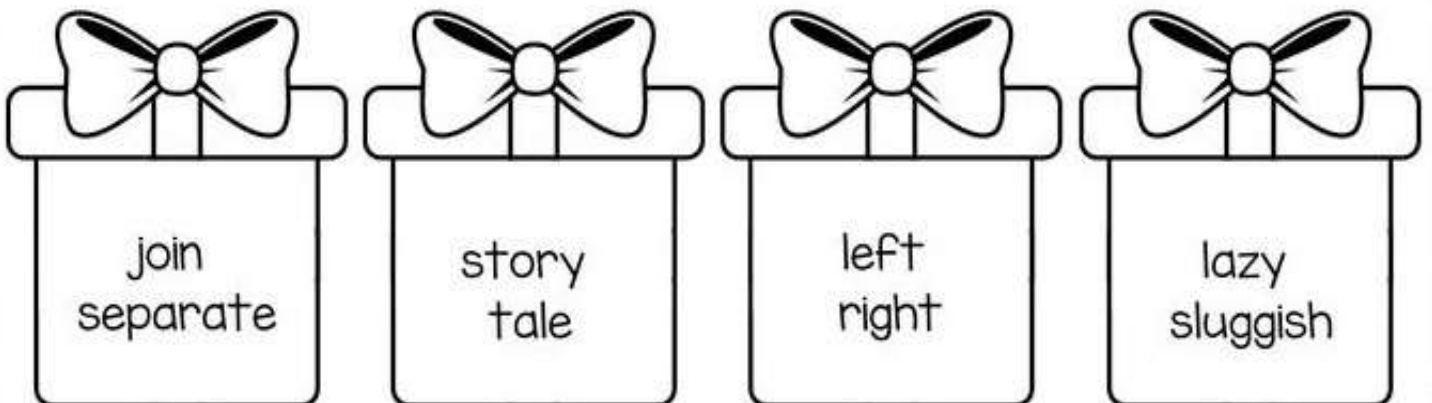
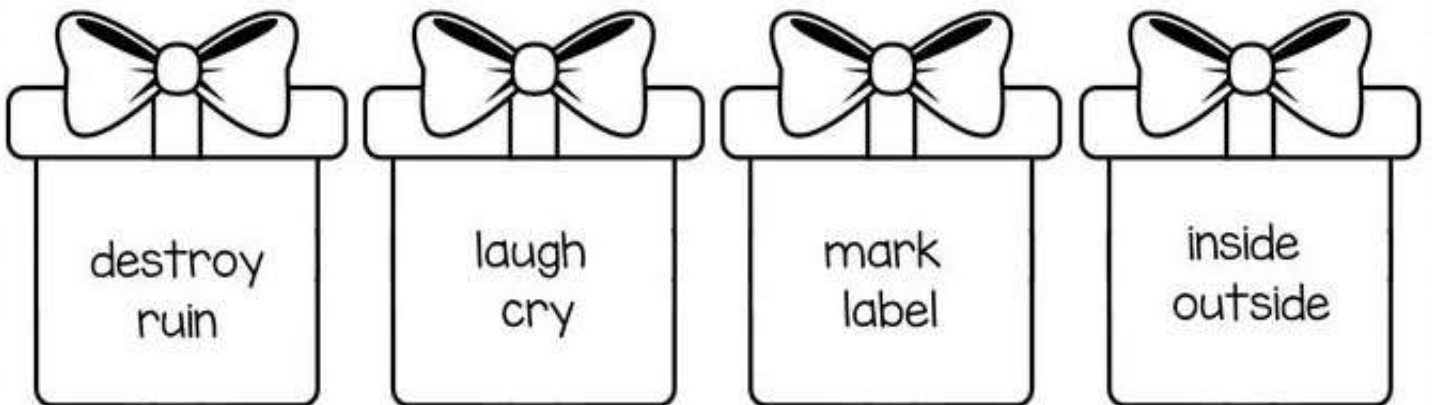
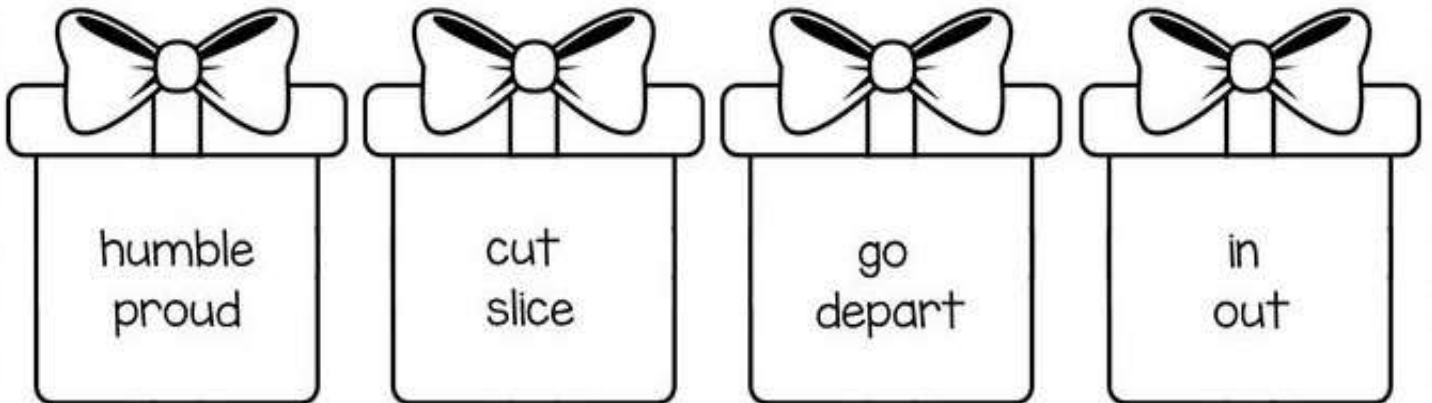

## Q6. Homophones: Crossword puzzle

**Directions:** Read the clues and use the word bank to complete the crossword puzzle.

sail
sale
flew
flu
knight
night
meat
meet
threw
through
weight
wait

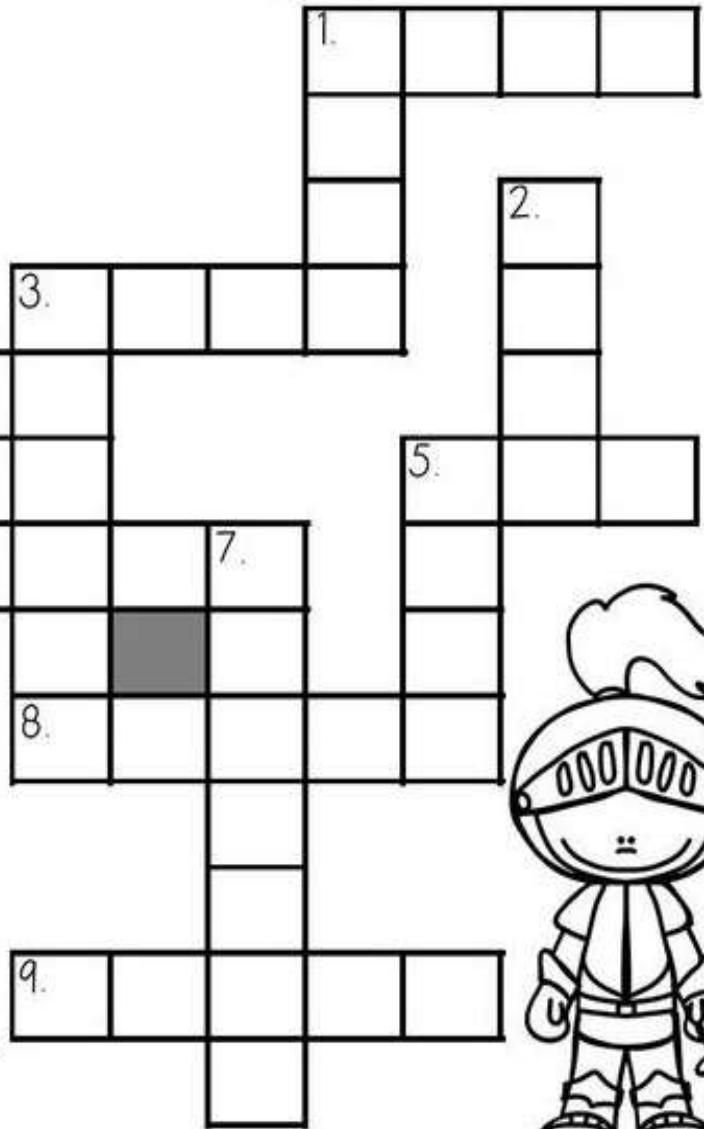

**Across:**

1. You can \_\_\_\_\_ my new friend.
3. We will \_\_\_\_\_ for the bus to come.
4. The store is having a big \_\_\_\_\_.
5. She was sick with the \_\_\_\_\_.
6. The \_\_\_\_\_ mounted his horse.
8. He \_\_\_\_\_ the ball to first base.
9. It was a long \_\_\_\_\_ and everyone was tired.

**Down:**

1. My dad cooked the \_\_\_\_\_ on the grill.
2. They went for a \_\_\_\_\_ around the island.
3. The baby gained a little \_\_\_\_\_.
5. We \_\_\_\_\_ our kites high.
7. He walked \_\_\_\_\_ the forest.

**Q7. Word Sudoku**

**PET WORDS:** The words or names that are used in the puzzle.

dog  
kitten  
hamster  
  
puppy  
bunny  
gerbil  
  
cat  
rabbit  
ferret

kitten	rabbit				cat			
ferret		bunny		puppy	gerbil			
puppy					rabbit		cat	ferret
	ferret		gerbil				kitten	puppy
	bunny			rabbit			ferret	gerbil
	puppy		kitten				rabbit	bunny
		dog	rabbit	gerbil	puppy			
bunny		puppy	cat					kitten
rabbit		ferret		dog				cat

**Q7. Word Sudoku**

**PET WORDS:** The words or names that are used in the puzzle.

dog  
kitten  
hamster  
  
puppy  
bunny  
gerbil  
  
cat  
rabbit  
ferret

kitten	rabbit				cat			
ferret		bunny		puppy	gerbil			
puppy					rabbit		cat	ferret
	ferret		gerbil				kitten	puppy
	bunny			rabbit			ferret	gerbil
	puppy		kitten				rabbit	bunny
		dog	rabbit	gerbil	puppy			
bunny		puppy	cat					kitten
rabbit		ferret		dog				cat

**Q8. Let's Spell!**

Some letters are missing in each word.

Write -ee or -ea in each word.

1) t r \_\_\_\_\_ s

5) s l \_\_\_\_\_ p

2) p l \_\_\_\_\_ s e

6) b \_\_\_\_\_ p

3) t \_\_\_\_\_ s e

7) f \_\_\_\_\_ t

4) t \_\_\_\_\_ c h

8) t r \_\_\_\_\_ t

Now add more words with **ee** and **ea** and write them in the correct boxes.

<u>ee</u>
-----------

<u>ea</u>
-----------

**Q8. Let's Spell!**

Some letters are missing in each word.

Write -ee or -ea in each word.

1) t r \_\_\_\_\_ s

5) s l \_\_\_\_\_ p

2) p l \_\_\_\_\_ s e

6) b \_\_\_\_\_ p

3) t \_\_\_\_\_ s e

7) f \_\_\_\_\_ t

4) t \_\_\_\_\_ c h

8) t r \_\_\_\_\_ t

Now add more words with **ee** and **ea** and write them in the correct boxes.

<u>ee</u>
-----------

<u>ea</u>
-----------



# GWALIOR GLORY SCHOOL

Class : III

SUMMER HOLIDAY HOMEWORK

HINDI (2025-26)

Name : \_\_\_\_\_ Sec. : \_\_\_\_\_ Roll No. : \_\_\_\_\_ Date : \_\_\_\_\_

NOTE: (1) प्रतिदिन एक पेज सुलेख का अभ्यास करिए।

(2) व्याकरण पुस्तक में से विलोम शब्द एवं वचन याद करिए।

(1) जल संरक्षण से संबंधित एक पोस्टर (ए4 साइज पेज पर) बनाइए एवं जल के संरक्षण के पाँच उपाय अपने शब्दों में लिखिए।

(2) तालिका को पूरा करिए।

राज्य	भाषा	लिपि
क) पंजाब	_____	_____
ख) ओडिशा	_____	_____
ग) महाराष्ट्र	_____	_____

(3) दिन, महीने और साल (वर्ष) द्वारा खाली स्थान भरो।

क) पृथ्वी दिवस \_\_\_\_\_ महीने में मनाया जाता है।

ख) साल के तीसरे महीने का नाम \_\_\_\_\_ है।

ग) मेरा जन्मदिवस \_\_\_\_\_ के महीने में आता है।

घ) रविवार का दूसरा नाम \_\_\_\_\_ है।

ङ) "श" से शुरू होने वाले दिन \_\_\_\_\_ और \_\_\_\_\_ हैं।

(4) बताओ तो जाने:—

क) सप्ताह के आखिरी दिन का नाम — \_\_\_\_\_

ख) पर्यावरण दिवस कब मनाया जाता है — \_\_\_\_\_

ग) गुरु पूर्णिमा किस महीने में आती है — \_\_\_\_\_

(5) समान लय वाले शब्दों का मिलान करिए:—

(क)	(ख)
1) पीछे	सँवारे
2) पसारे	नीचे
3) पाओ	मटका
4) झटका	पतीले
5) रसीले	जाओ

(6) दिए गए स्थान पर विलोम शब्द लिखिए:-



(7) वर्णों को उलटकर लिखिए और नए शब्द बनाइए:-

- 1) नदी — \_\_\_\_\_
- 2) खीरा — \_\_\_\_\_
- 3) बस — \_\_\_\_\_
- 4) नीरा — \_\_\_\_\_
- 5) दावा — \_\_\_\_\_
- 6) रीना — \_\_\_\_\_

(8) दिए गए चित्रों के माध्यम से बंदर और मगरमच्छ की वार्तालाप को लिखिए:-

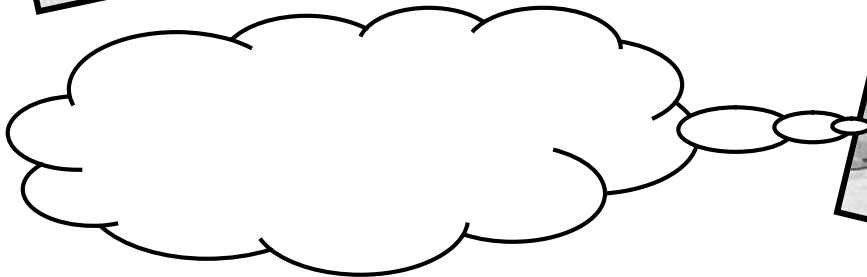
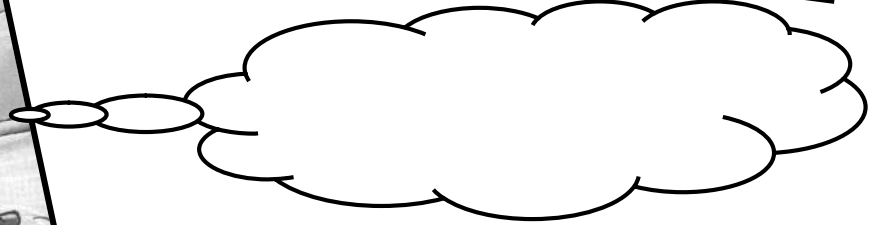
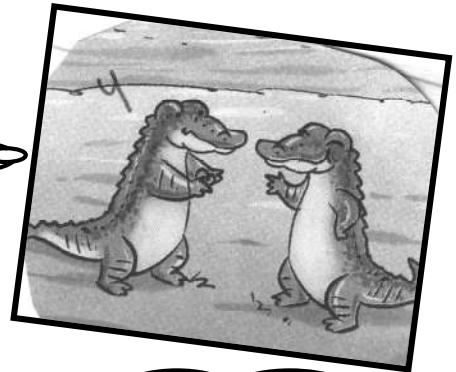
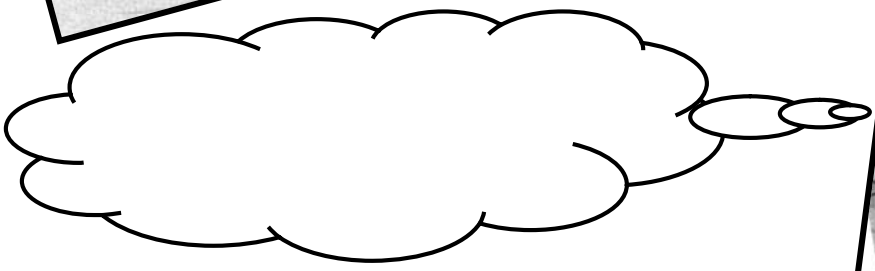
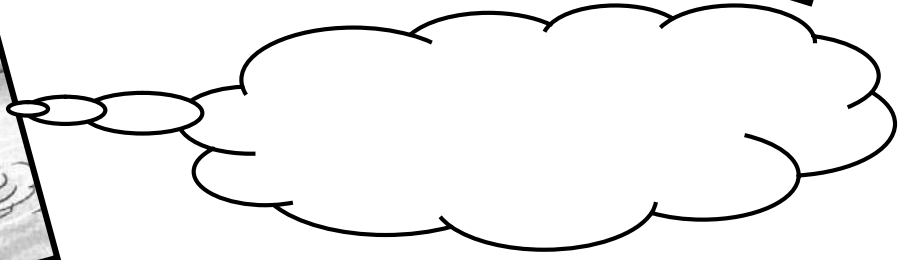
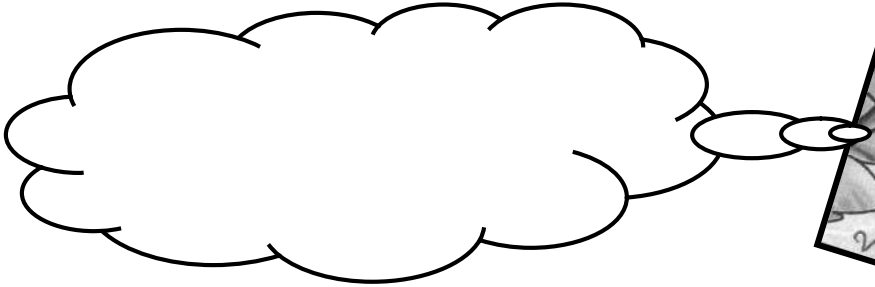
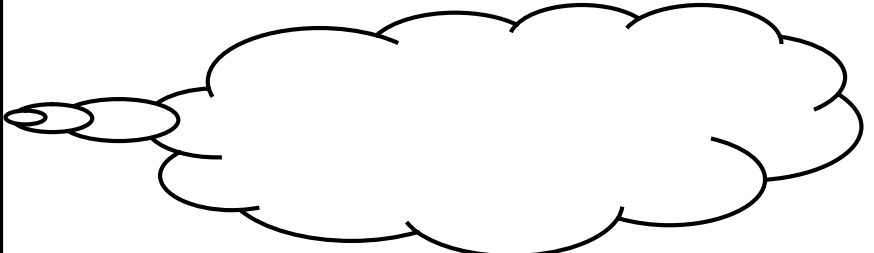

(9) बॉक्स में दिए शब्दों की मदद से कहानी पूरी कीजिए—

किनारे, कबूतर, जंगल, नदी, जान बचाई, चींटी, पत्ते पर बैठ गई,  
शिकारी, काटा, पेड़, सुनाई, डूब, पत्ता, चोंच, पैर, चूक गया,  
धन्यवाद, उड़ गया, मित्रता हो गई

एक \_\_\_\_\_ में एक नदी के \_\_\_\_\_ पर एक \_\_\_\_\_  
बैठा था। तभी उसे चीखने की आवाज़ \_\_\_\_\_ दी। कबूतर ने देखा  
\_\_\_\_\_ में एक चींटी \_\_\_\_\_ रही थी। कबूतर ने झट से पेड़  
से एक \_\_\_\_\_ तोड़ा और नदी में डूबती \_\_\_\_\_ के पास फेंक  
दिया। चींटी उस \_\_\_\_\_। तब कबूतर ने उस पत्ते को \_\_\_\_\_  
से पकड़कर बाहर निकाला। इस तरह उसने चींटी की \_\_\_\_\_। कुछ दिनों  
बाद चींटी ने देखा—एक पेड़ पर वही कबूतर बैठा डर के मारे काँप रहा था। थोड़ी दूर  
पर एक \_\_\_\_\_ बंदूक ताने खड़ा था। चींटी जल्दी से शिकारी के पास  
गई। उसके \_\_\_\_\_ पर उसने जोर से \_\_\_\_\_। शिकारी  
का निशाना \_\_\_\_\_। कबूतर झट से \_\_\_\_\_। कबूतर ने  
चींटी को \_\_\_\_\_ कहा। इस तरह चींटी और कबूतर दोनों में  
\_\_\_\_\_।

# GWALIOR GLORY SCHOOL

## SUMMER HOLIDAY HOMEWORK MATHEMATICS (2025-26)

Class : III

Name : \_\_\_\_\_ Sec. : \_\_\_\_\_ Roll No. : \_\_\_\_\_ Date : \_\_\_\_\_

- 1) Replace one of the digits of 5648 by 9 such that the number increases by 300. \_\_\_\_\_
- 2) Write any 4-digit number of your choice, form another number by reversing the digits. Add the two numbers. Then subtract the smaller number from the bigger number.

Numbers : \_\_\_\_\_

Add

Subtract

- 3) A number multiplied by itself gives 10000. What is the number? \_\_\_\_\_

- 4) (a) Solve the following:-

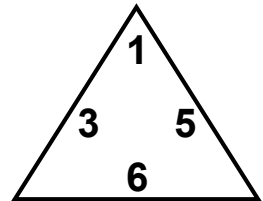
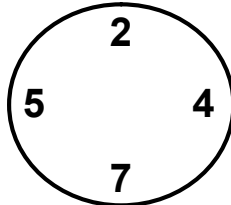
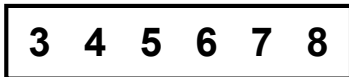

- a) It is in both the rectangle and the circle.
- b) It is not in the triangle.
- c) It is greater than 5.

- 4) (b) What number is it? \_\_\_\_\_

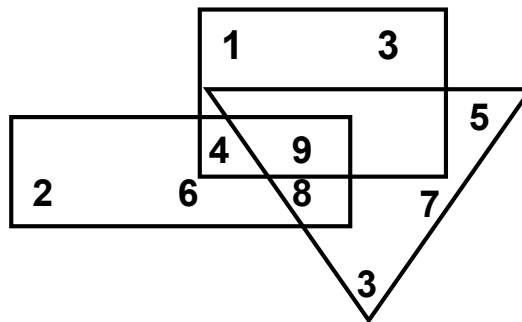

- ◆ It is in the triangle. It is not an even number.
- ◆ It is in the rectangle and square.
- ◆ What number is it? \_\_\_\_\_

5) **Number Hive:-**

Add up the numbers and colour the shapes as per the colour scheme given below.

3+3    5+3    7+1    6+4    4+3

6+3    2+5

2+4    8+2    7+2

5+1    3+6    4+3    4+4

2+6    3+3    7+1

4+1    7+2    9+1    3+3

6+3    2+8    5+2    3+4

1+6    7+1    2+5    9+1

3+5    5+1    5+2

7+2    2+2    3+5

5+3    1+7    4+3

3+1    4+5    2+8

5+5    1+6    6+4

2+2    8+1

4	5	6	7	8	9	10
Red	Blue	Yellow	Green	Brown	Yellow	Brown

6) Use the hints to fill in the missing digits in the three digit numbers. Then answer the given questions. HINTS:-

- 1) In (A), the face value of the missing digit is 4.
- 2) In (B) the missing digit is 1 more than the digit in the tens place.
- 3) In (C) the place value of the digit in the tens place is 70 and all digits are the same.
- 4) In (D) the missing digit is the biggest one digit number.

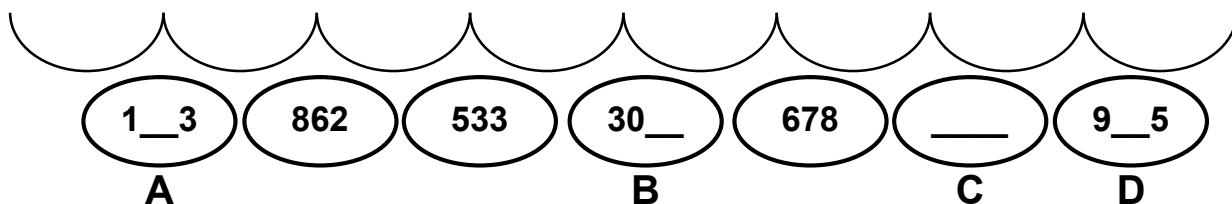

Answer the following after filling the missing digits.

a) Write the greatest and the smallest number

\_\_\_\_\_

b) Arrange all the numbers in increasing order.

\_\_\_\_\_

6) Use the hints to fill in the missing digits in the three digit numbers. Then answer the given questions. HINTS:-

- 1) In (A), the face value of the missing digit is 4.
- 2) In (B) the missing digit is 1 more than the digit in the tens place.
- 3) In (C) the place value of the digit in the tens place is 70 and all digits are the same.
- 4) In (D) the missing digit is the biggest one digit number.

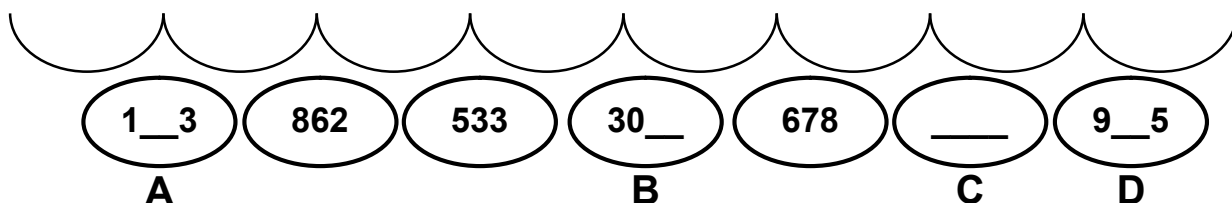

Answer the following after filling the missing digits.

a) Write the greatest and the smallest number

\_\_\_\_\_

b) Arrange all the numbers in increasing order.

\_\_\_\_\_

7) Solve and search in the given box:-

<input checked="" type="checkbox"/> $10 \times 5 = 50$
<input type="checkbox"/> $8 \times 5 =$
<input type="checkbox"/> $5 \times 3 =$
<input type="checkbox"/> $2 \times 5 =$
<input type="checkbox"/> $4 \times 5 =$
<input type="checkbox"/> $5 \times 11 =$
<input type="checkbox"/> $7 \times 5 =$
<input type="checkbox"/> $5 \times 5 =$
<input type="checkbox"/> $6 \times 5 =$
<input type="checkbox"/> $5 \times 9 =$
<input type="checkbox"/> $1 \times 5 =$
<input type="checkbox"/> $12 \times 5 =$

2	3	6	3	3	9	10	9
10	12	5	60	12	1	5	15
20	0	14	2	3	10	50	8
9	7	5	35	6	8	7	1
1	7	8	4	8	5	4	5
4	39	0	22	8	40	8	3
2	5	10	24	33	6	5	15
3	9	2	2	5	0	5	8
5	2	4	5	20	6	5	2
11	0	8	2	8	9	25	0
55	5	4	1	6	5	30	1
5	9	45	0	4	0	3	5
4	3	1	8	7	12	7	5

7) Solve and search in the given box:-

<input checked="" type="checkbox"/> $10 \times 5 = 50$
<input type="checkbox"/> $8 \times 5 =$
<input type="checkbox"/> $5 \times 3 =$
<input type="checkbox"/> $2 \times 5 =$
<input type="checkbox"/> $4 \times 5 =$
<input type="checkbox"/> $5 \times 11 =$
<input type="checkbox"/> $7 \times 5 =$
<input type="checkbox"/> $5 \times 5 =$
<input type="checkbox"/> $6 \times 5 =$
<input type="checkbox"/> $5 \times 9 =$
<input type="checkbox"/> $1 \times 5 =$
<input type="checkbox"/> $12 \times 5 =$

2	3	6	3	3	9	10	9
10	12	5	60	12	1	5	15
20	0	14	2	3	10	50	8
9	7	5	35	6	8	7	1
1	7	8	4	8	5	4	5
4	39	0	22	8	40	8	3
2	5	10	24	33	6	5	15
3	9	2	2	5	0	5	8
5	2	4	5	20	6	5	2
11	0	8	2	8	9	25	0
55	5	4	1	6	5	30	1
5	9	45	0	4	0	3	5
4	3	1	8	7	12	7	5





B) Imagine that you are playing with your friends and one of you gets hurt. Write down the steps you would take to provide first aid. You can use the clues given.

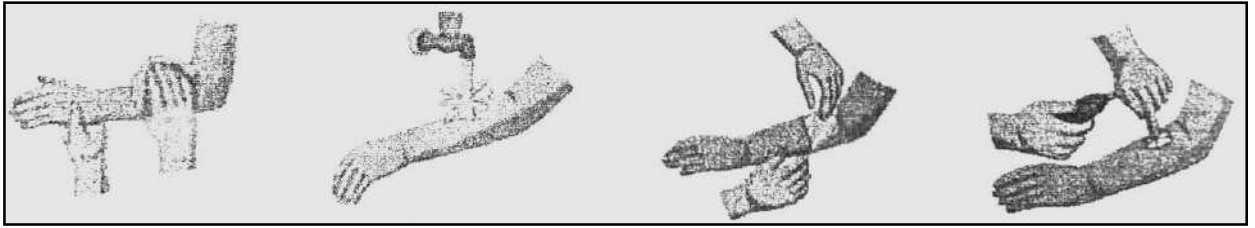

**Clues:**    apply gentle pressure,                  clean the wound,  
                  apply antibiotic cream,              cover the wound,                  go to elders.

---



---



---



---



---



---

3) **CAPACITY BUILDING ACTIVITY**

A) Colour the flags of the countries given. Write their capital cities and nationalities.

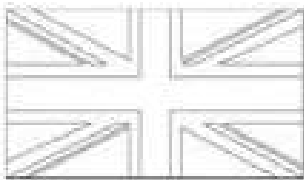

(JOHN)  
ENGLAND

---



---

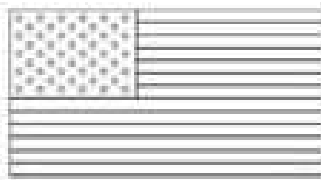

(BILL)  
The USA

---



---

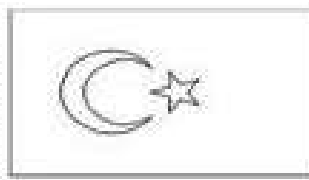

(AHMET)  
TURKEY

---



---

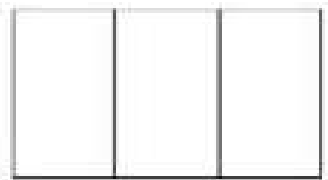

(ADRIANNA)  
FRANCE

---



---

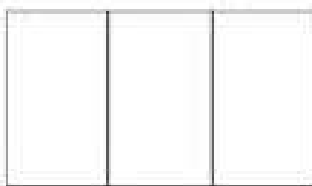

(ANITA)  
ITALY

---



---



(HANS)  
GERMANY

---



---



(LOPEZ)  
SPAIN

---



---

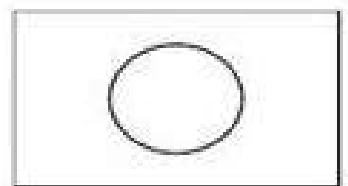

(AKIKO)  
JAPAN

---



---



(LEE)  
CHINA

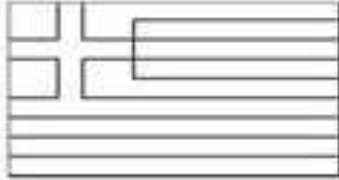

(YANNIS)  
GREECE

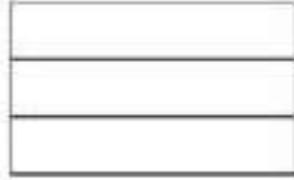

(ANASTASIA)  
RUSSIA



(NABIEL)  
AUSTRALIA

- 1) Where is Yannis From? \_\_\_\_\_
- 2) Where is Anastasia from? \_\_\_\_\_
- 3) What is the capital city of China? \_\_\_\_\_
- 4) What is the capital city of Germany? \_\_\_\_\_
- 5) What nationality is Adrianna? \_\_\_\_\_
- 6) What nationality is Ahmet? \_\_\_\_\_
- 7) Where is Nabel from? \_\_\_\_\_
- 8) Where is Hans From? \_\_\_\_\_
- 9) Is Tokyo the capital city of Japan? \_\_\_\_\_
- 10) Is London the capital city of the USA? \_\_\_\_\_
- 11) Is Lee from Italy? \_\_\_\_\_
- 12) Is Anita French? \_\_\_\_\_

(B)

# Plants Need Animals

Fill in the blanks with the help of the word bank given.



1. Some \_\_\_\_\_<sup>1</sup> \_\_\_\_\_<sup>2</sup> spread pollen.
2. In some cases, pollen may stick to an animal's \_\_\_\_\_<sup>3</sup> when it brushes against a flower.
3. The pollen is \_\_\_\_\_<sup>4</sup> \_\_\_\_\_<sup>5</sup> on another flower.
4. Birds that drink \_\_\_\_\_<sup>6</sup> \_\_\_\_\_<sup>7</sup> move pollen too.
5. Flowers use \_\_\_\_\_<sup>8</sup> \_\_\_\_\_<sup>9</sup> when they make seeds.
6. Animals help spread \_\_\_\_\_<sup>10</sup>.
7. Some seeds have \_\_\_\_\_<sup>11</sup> \_\_\_\_\_<sup>12</sup> that catch on an animal's fur.
8. Other seeds travel by wind or \_\_\_\_\_<sup>13</sup> \_\_\_\_\_<sup>14</sup>.
9. Squirrels may bury \_\_\_\_\_<sup>15</sup> \_\_\_\_\_<sup>16</sup> and then forget them.
10. Some animals may eat \_\_\_\_\_<sup>17</sup> and then drop the seeds in a new place.
11. A bird may eat a seed and \_\_\_\_\_<sup>18</sup> \_\_\_\_\_<sup>19</sup> it in a new place.
12. Animals can help plants by \_\_\_\_\_<sup>20</sup> \_\_\_\_\_<sup>21</sup> \_\_\_\_\_<sup>22</sup> \_\_\_\_\_<sup>23</sup> their pollen and their seeds.

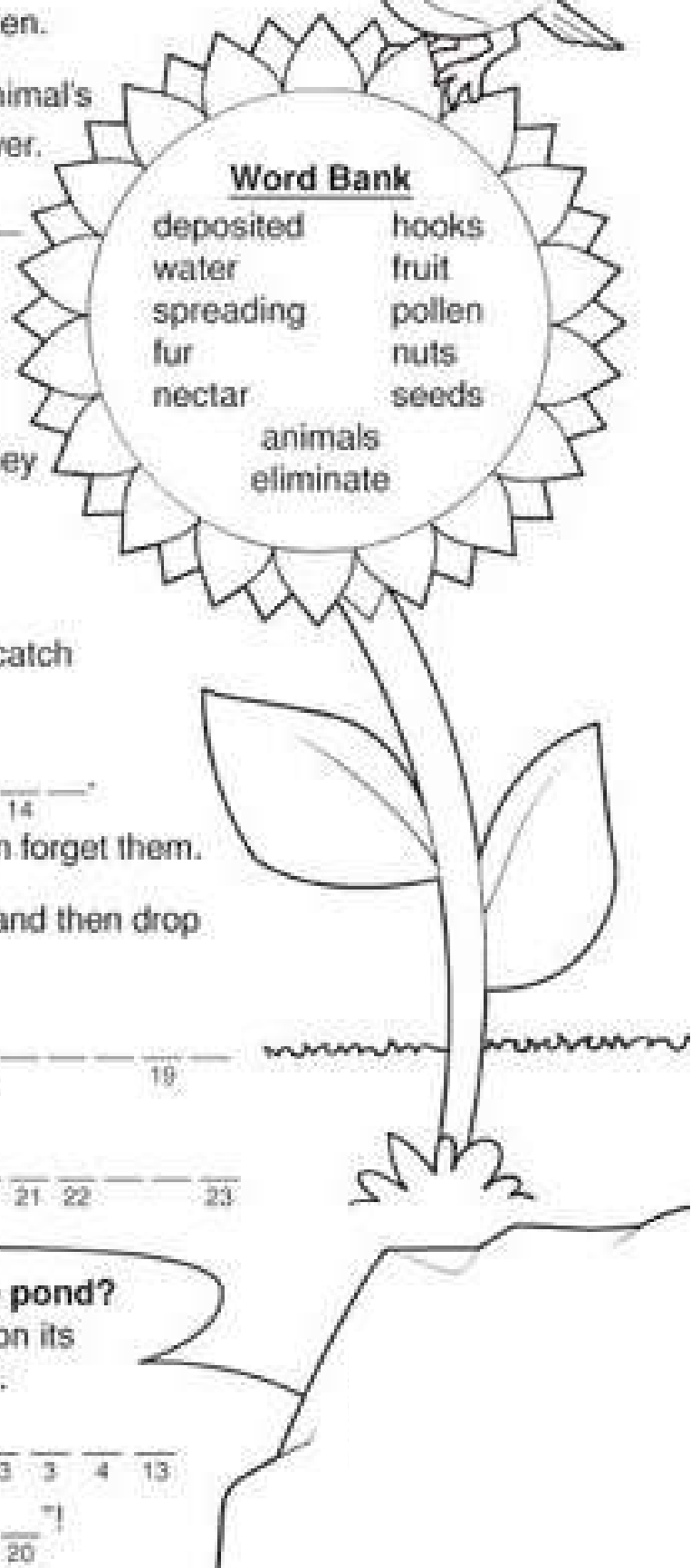

**Word Bank**  
deposited      hooks  
water          fruit  
spreading      pollen  
fur              nuts  
nectar          seeds  
animals  
eliminate

**Why did Mr. Bird drop seeds into the pond?**

To solve the riddle, write each letter on its matching numbered line or lines.

\_\_\_\_<sup>11</sup> \_\_\_\_<sup>10</sup>    \_\_\_\_<sup>13</sup> \_\_\_\_<sup>6</sup> \_\_\_\_<sup>1</sup> \_\_\_\_<sup>19</sup> \_\_\_\_<sup>5</sup> \_\_\_\_<sup>22</sup>    \_\_\_\_<sup>17</sup> \_\_\_\_<sup>6</sup>    \_\_\_\_<sup>23</sup> \_\_\_\_<sup>3</sup> \_\_\_\_<sup>4</sup> \_\_\_\_<sup>13</sup>  
\_\_\_\_<sup>13</sup> \_\_\_\_<sup>21</sup> \_\_\_\_<sup>16</sup> \_\_\_\_<sup>14</sup> \_\_\_\_<sup>7</sup>    \_\_\_\_<sup>18</sup> \_\_\_\_<sup>9</sup> \_\_\_\_<sup>2</sup> \_\_\_\_<sup>12</sup> \_\_\_\_<sup>15</sup> \_\_\_\_<sup>20</sup>

◆) Do pg 14 and 15 in EVS book, "Our Wondrous world".

# GWALIOR GLORY SCHOOL

## SUMMER HOLIDAY HOMEWORK

GK (2025-26)

Class : III

Name : \_\_\_\_\_ Sec. : \_\_\_\_\_ Roll No. : \_\_\_\_\_ Date : \_\_\_\_\_

1) Name the inventors of the following:-

- a) Steam engine \_\_\_\_\_
- b) Radio and wireless communication \_\_\_\_\_
- c) Electric bulb \_\_\_\_\_
- d) Telephone \_\_\_\_\_
- e) Cell Phone \_\_\_\_\_
- f) Airplane \_\_\_\_\_
- g) Cinema \_\_\_\_\_
- h) Modern Thermometer \_\_\_\_\_
- i) Car \_\_\_\_\_
- j) Artificial Intelligence \_\_\_\_\_

2) Write the full form of the abbreviation one example is given below:-

- PIN – Postal Index Number
- UPI – \_\_\_\_\_
- ASAP – \_\_\_\_\_
- PTO – \_\_\_\_\_
- LPG – \_\_\_\_\_
- ATM – \_\_\_\_\_
- OTP – \_\_\_\_\_
- AM / PM – \_\_\_\_\_
- AC – \_\_\_\_\_
- DIY – \_\_\_\_\_

**3) Know my city:**

Name of the city you live in. : \_\_\_\_\_

Which Indian state it belong to? : \_\_\_\_\_

Nickname of the city. : \_\_\_\_\_

Famous food of your city. : \_\_\_\_\_

Name of the airport. : \_\_\_\_\_

Name of the famous stadium. : \_\_\_\_\_

Name the legendary musician of your city. : \_\_\_\_\_

One famous river flowing through your city. : \_\_\_\_\_

Famous dam of the city. : \_\_\_\_\_

Heritage buildings or sites of the city:

1. \_\_\_\_\_ 2. \_\_\_\_\_

3. \_\_\_\_\_ 4. \_\_\_\_\_

**4) Name them:-**

a) A flower that rotate its face with the sun \_\_\_\_\_

b) An edible flower \_\_\_\_\_

c) A plant that eats insects \_\_\_\_\_

d) An animal which cannot jump \_\_\_\_\_

e) A bird that can fly backwards \_\_\_\_\_

f) One animal that hibernates [ sleep for months ] \_\_\_\_\_

g) An insect that hear with their legs. \_\_\_\_\_

h) A tailless animal \_\_\_\_\_

i) A bird that share its name with a fruit \_\_\_\_\_

j) An animal with a shell \_\_\_\_\_

**5) On an A/4 sized white paper draw and colour these “Product Safety I-cons”:-**

a) Fragile / Breakable

b) Reduce / Reuse / Recycle

c) Non edible

d) Vegan food

e) Vegetarian

f) Non Vegetarian

g) Highly Flammable

# **GWALIOR GLORY SCHOOL**

**Class : III**

## **SUMMER HOLIDAY HOMEWORK COMPUTER (2025-26)**

Name : \_\_\_\_\_ Sec. : \_\_\_\_\_ Roll No. : \_\_\_\_\_ Date : \_\_\_\_\_

- ◆ Using Microsoft Word application prepare a scrap book of atleast 5-8 sheets on below mentioned topic with different fonts:- [ ANY ONE ]

(a) Me and My Family

(b) Different types of Berries.

(c) Type of keys on the keyboard and their use.

(d) Any 5 smart gadgets such as:-

Smart Door Bell, Camera, Smart Watch, Smart T.V., Smart Fan , Alexa etc.

→ Their defination and use.

- ◆ Dear Students,

As we have learned in previous class, that typing on keyboard must be practiced using both the hands. So, observe the keys on the given picture and colour the keys with the colour code mentioned on respective fingers of left and Right Hand.

# **GWALIOR GLORY SCHOOL**

**Class : III**

## **SUMMER HOLIDAY HOMEWORK COMPUTER (2025-26)**

Name : \_\_\_\_\_ Sec. : \_\_\_\_\_ Roll No. : \_\_\_\_\_ Date : \_\_\_\_\_

- ◆ Using Microsoft Word application prepare a scrap book of atleast 5-8 sheets on below mentioned topic with different fonts:- [ ANY ONE ]

(a) Me and My Family

(b) Different types of Berries.

(c) Type of keys on the keyboard and their use.

(d) Any 5 smart gadgets such as:-

Smart Door Bell, Camera, Smart Watch, Smart T.V., Smart Fan , Alexa etc.

→ Their defination and use.

- ◆ Dear Students,

As we have learned in previous class, that typing on keyboard must be practiced using both the hands. So, observe the keys on the given picture and colour the keys with the colour code mentioned on respective fingers of left and Right Hand.

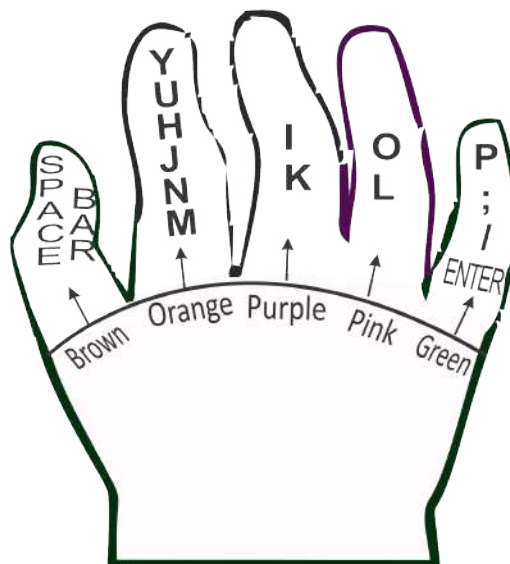
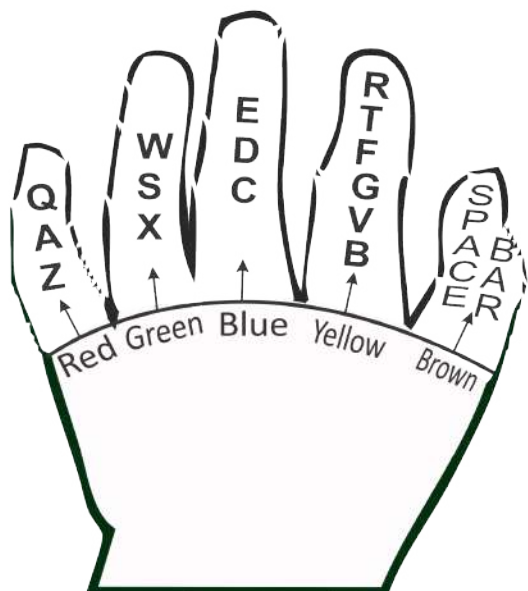
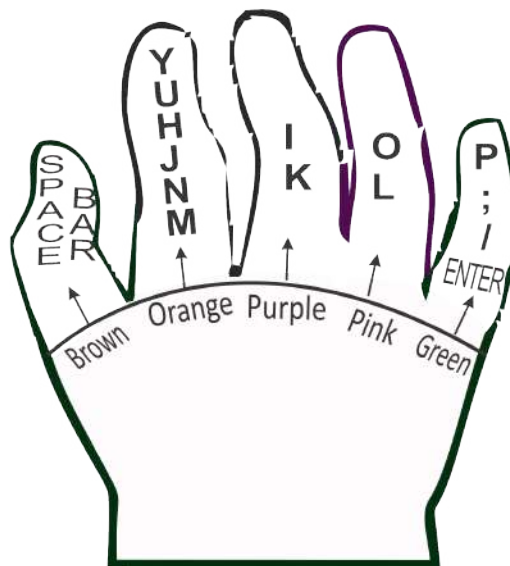
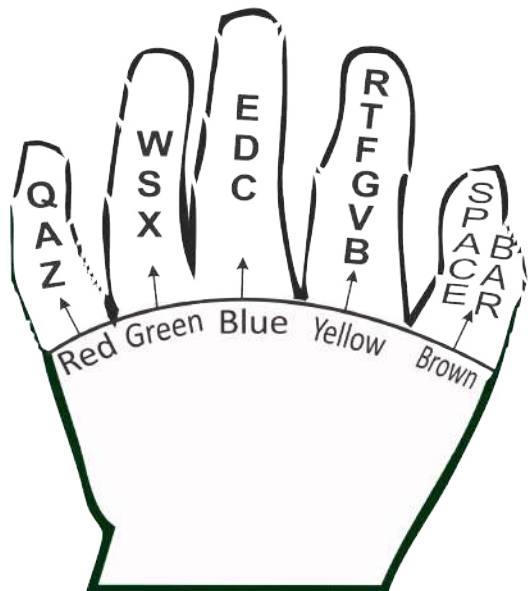



# GWALIOR GLORY SCHOOL

Class : III

SUMMER HOLIDAY HOMEWORK (2025-26)

Art & Craft

Name : \_\_\_\_\_ Sec. : \_\_\_\_\_ Roll No. : \_\_\_\_\_ Date : \_\_\_\_\_

## DRAWING

1) WORKSHEET-1: Draw using by following direction in each box:-

**Example Given Below:-**

Lines like ocean waves

Lines like rain

Line like clouds

Lines thin as thread

Lines round like buttons

Line jagged as rocks

Lines like wood grain

Lines liike fuzzy sweater

Lines like grass

2) **WORKSHEET-2:** Symmetry art drawing.

Example:-

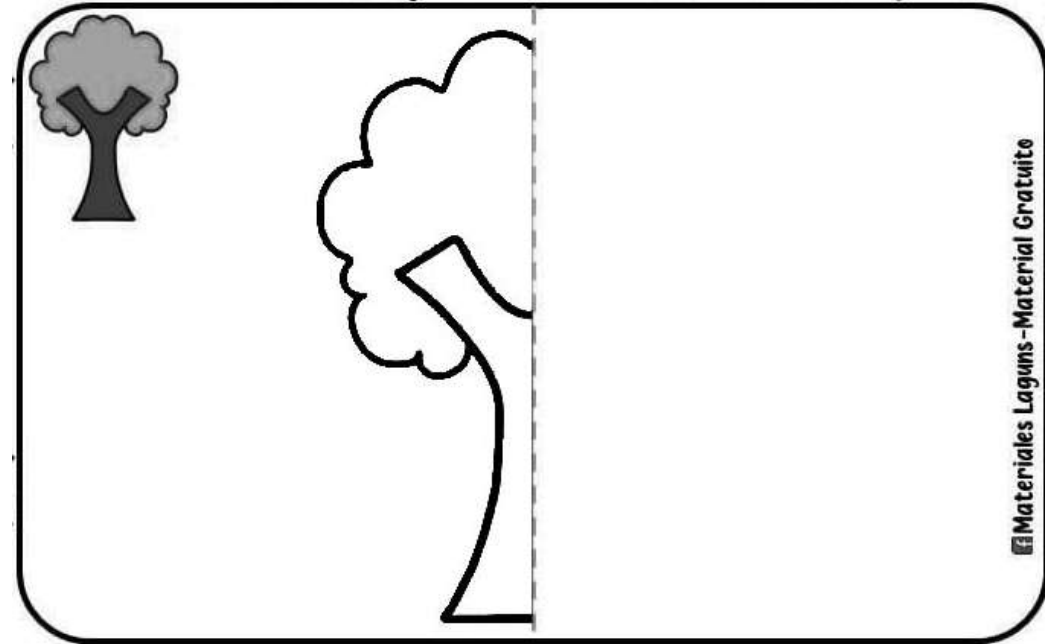
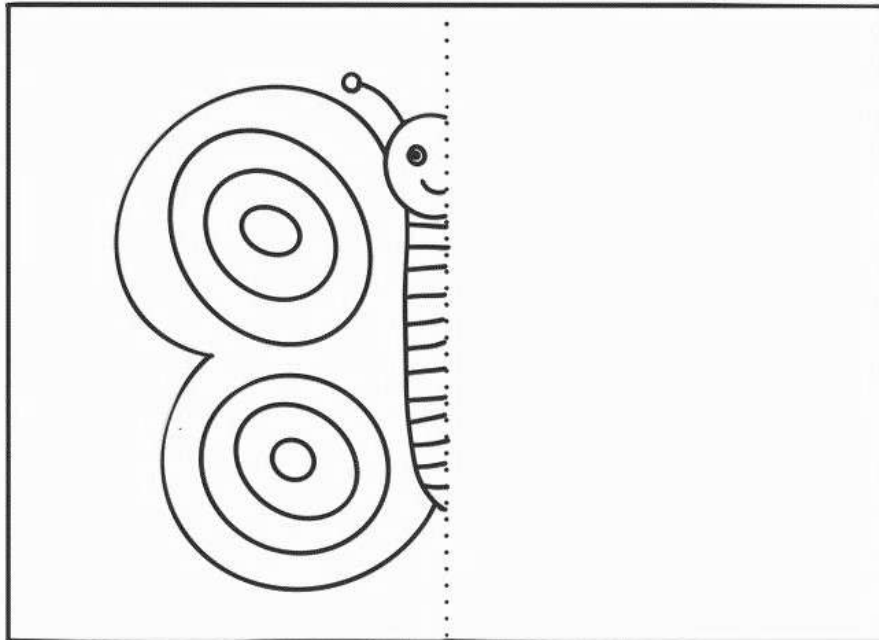
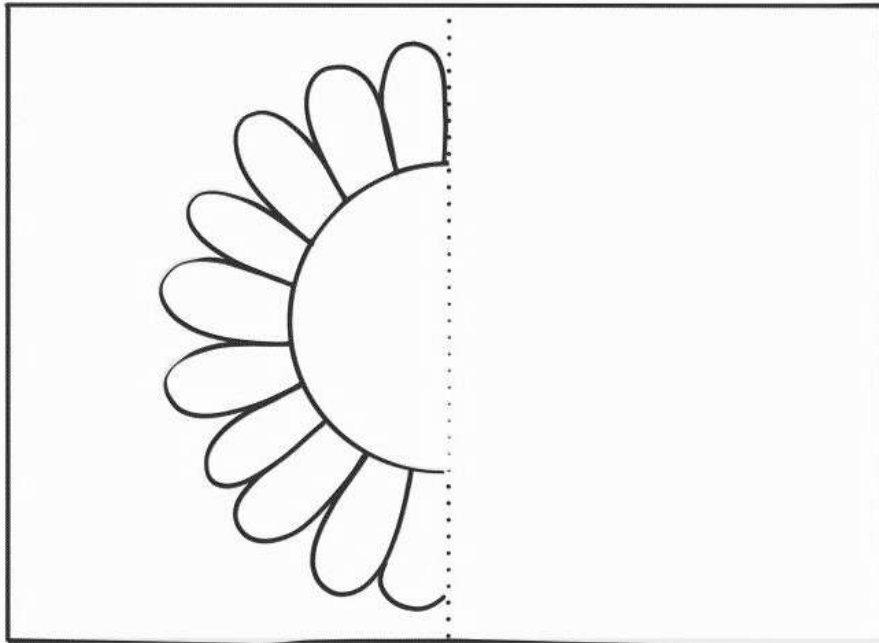

Materials Laguns - Material Gratuito

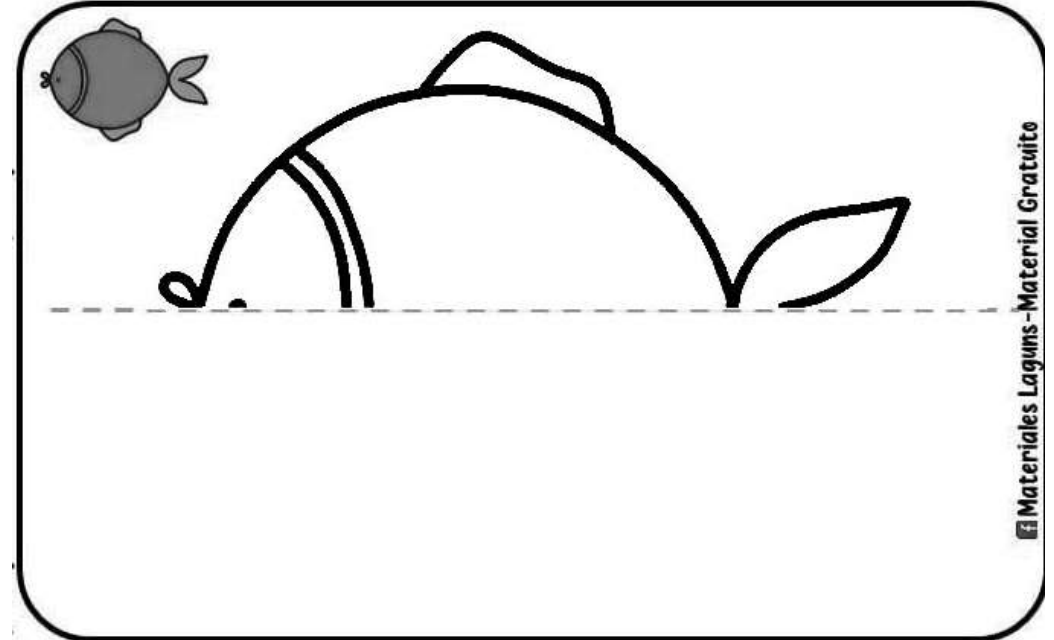

Materials Laguns - Material Gratuito

3) **WORKSHEET-3:**

Make hand and decorate it with beautiful print.

**Example Given Below:-**



4) Draw a scenery of your choice and use lines and pattern to complete the drawing.

**Example:**

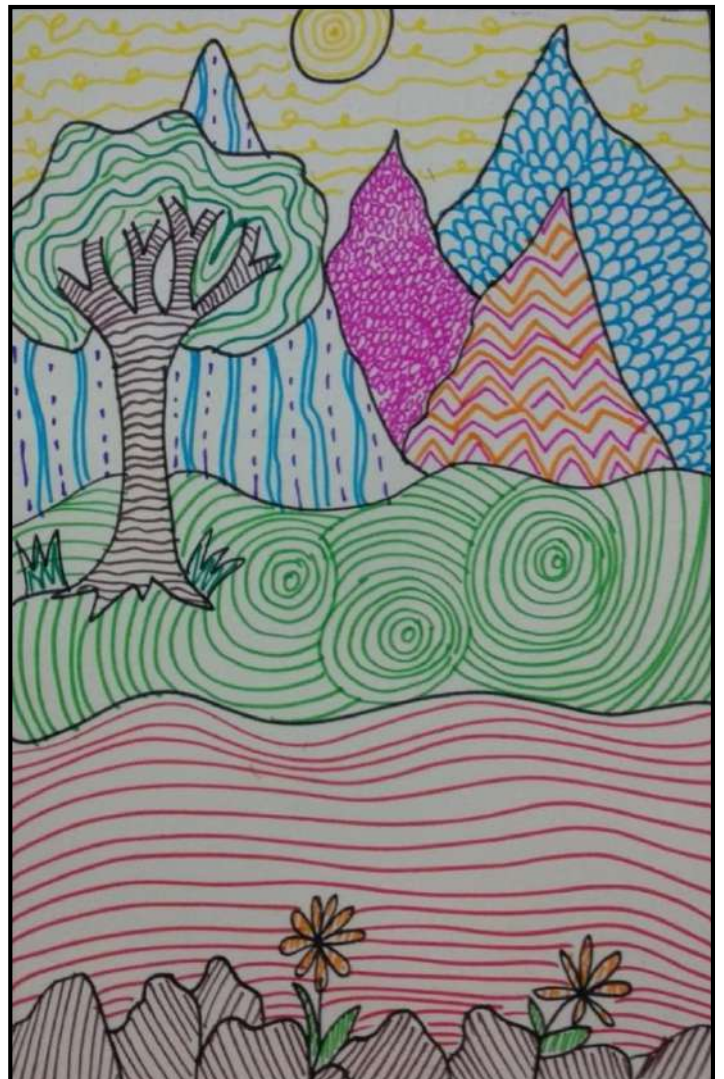

**Note: All work should be done by A-4 Size Sheet**

5) Complete the given picture with your own imagination.

**Example:**

What's under the sea?

